

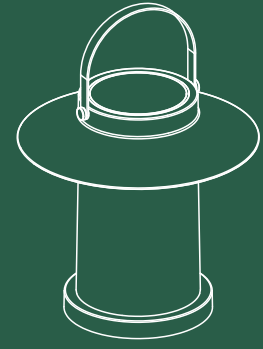

nordlux®

nordlux



TEMPLE 30 TO GO
Item N°: 2218325031
Dc: 2278575
Galvanneerd
Verzinkt
Galvanneerd
Galvanneerd
Gegalvaniseerd



nordlux®

- LED 2W
- 15 YEAR GUARANTEE
- SOLAR PANEL
- INCL. CHARGING CABLE
- INCL. BATTERY
- IP54 WATER RESISTANT
- 3000 KELVIN

DESIGNED FOR SEASIDE USE
TEMPLE 30 TO GO



nordlux®

- LED 2W
- 15 YEAR GUARANTEE
- SOLAR PANEL
- INCL. CHARGING CABLE
- INCL. BATTERY
- IP54 WATER RESISTANT
- 3000 KELVIN

DESIGNED FOR SEASIDE USE
TEMPLE 30 TO GO

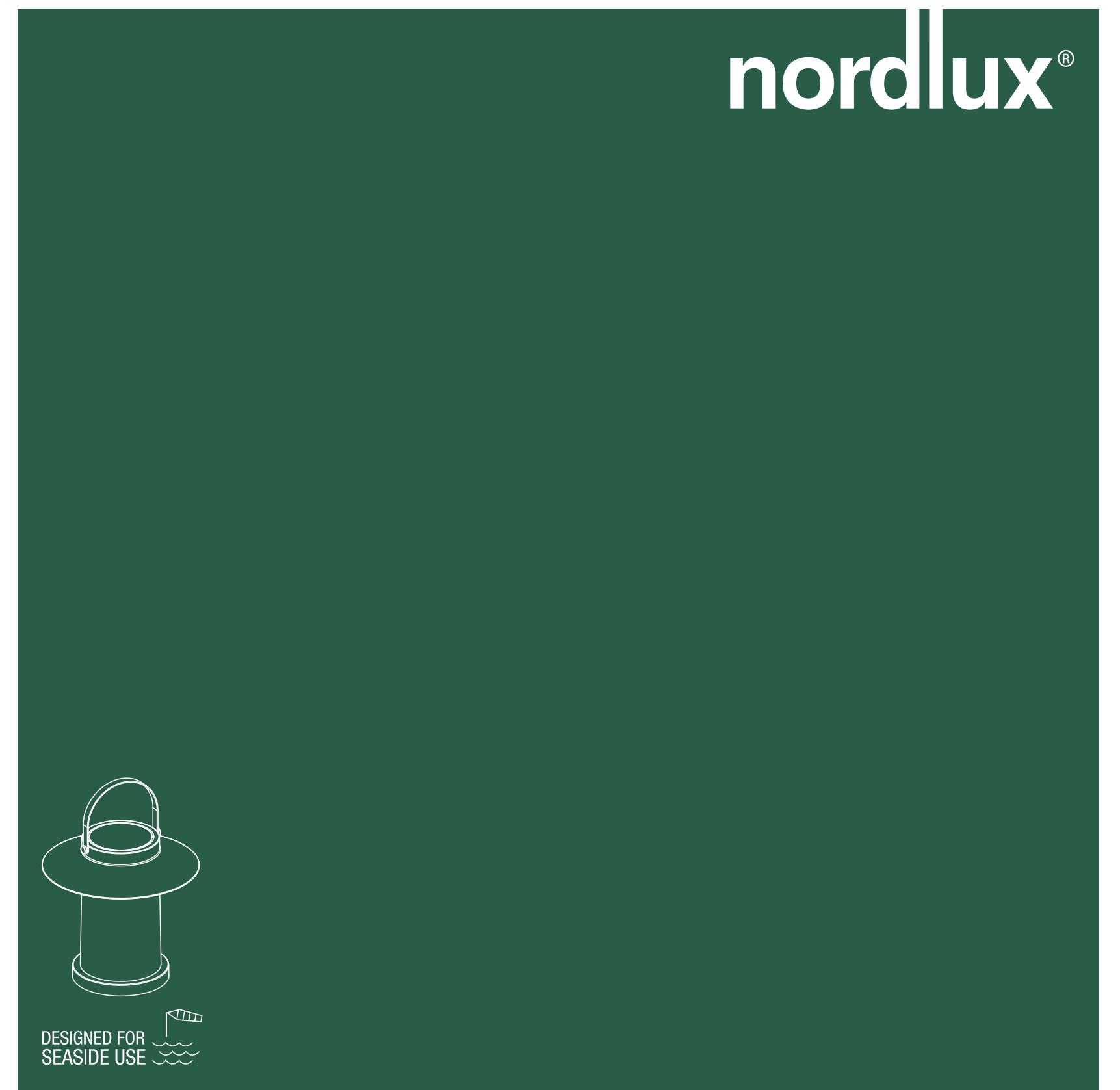

nordlux®

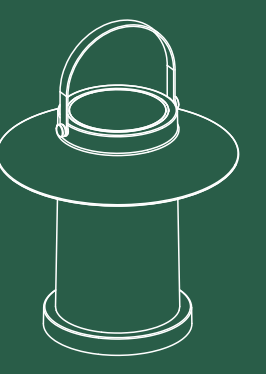

DESIGNED FOR SEASIDE USE

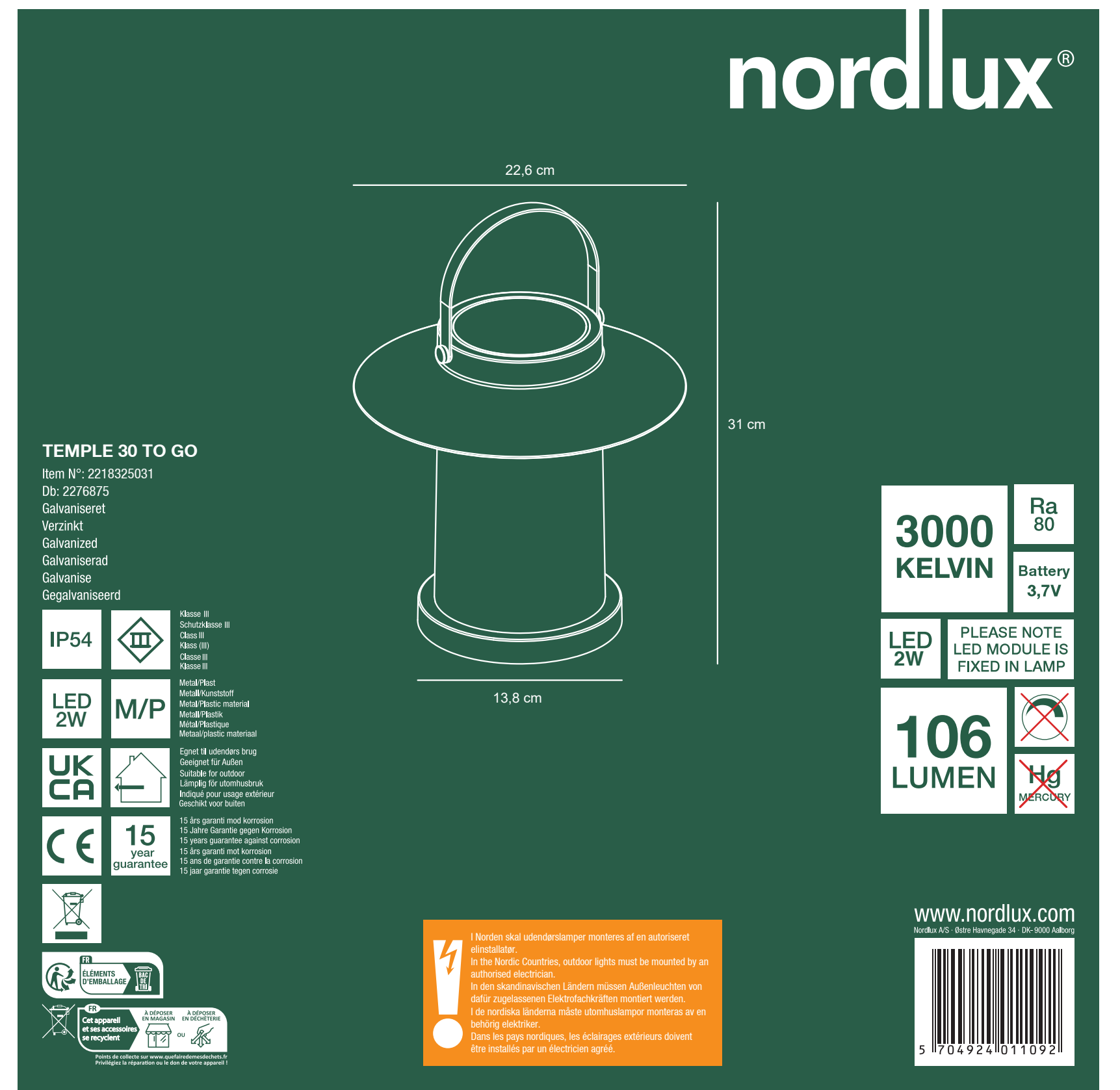

nordlux®

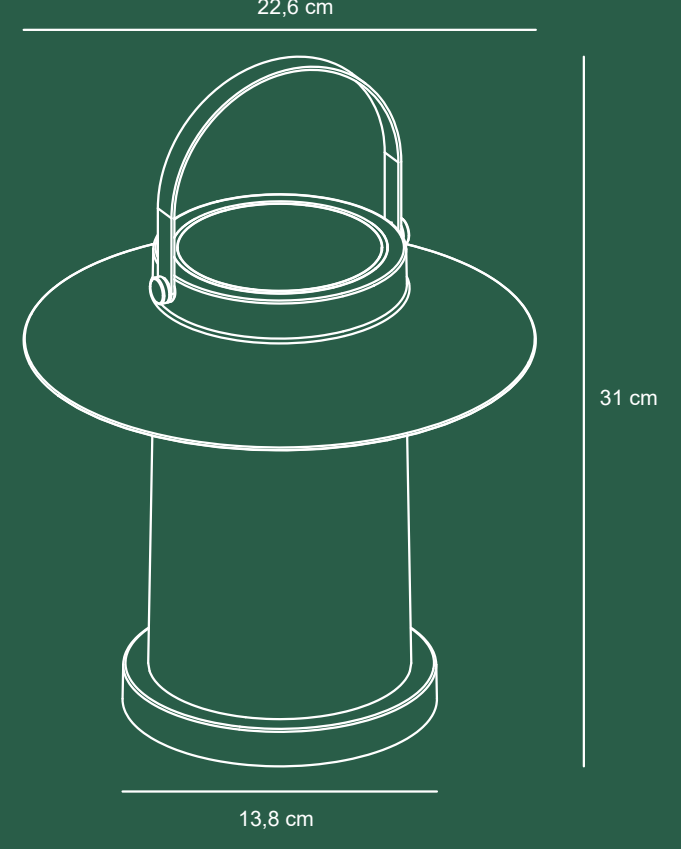

TEMPLE 30 TO GO
Item N°: 2218325031
Dc: 2278575
Galvanneerd
Verzinkt
Galvanneerd
Galvanneerd
Gegalvaniseerd

- IP54
- LED 2W
- UK CA
- CE
- 15 YEAR GUARANTEE
- RoHS
- RECYCLED
- RECYCLED
- RECYCLED

- 3000 KELVIN
- Ra 80
- Battery 3.7V
- LED 2W
- PLEASE NOTE LED MODULE IS FIXED IN LAMP
- 106 LUMEN
- Hg

! **Warning:** Read the instruction manual before use.
In the UK, Canada, outdoor lights must be mounted by all professional electricians.
In the US, Canada, outdoor lights must be mounted by all professional electricians.
In the UK, Canada, outdoor lights must be mounted by all professional electricians.
In the US, Canada, outdoor lights must be mounted by all professional electricians.

www.nordlux.com
5 708324 103924

AAD: 26102023 NS
Nordlux UK
Unit 22, Dearfield Court
BB7 1QS Colthorpe Lancashire
01200422777